

FEATURES

- Tub capacity 12 with storage capacity of 10 below
- Kick plate and bumper guard standard
- Excellent for building a dipping cabinet
- Best in class thermal sliding glass lids
- Lock and key
- Mobility casters for effortless relocation and cleaning
- Easy to clean
- Temperature Range: -23C to -13C / -10°F to 7°F



CONSTRUCTION

- Cold wall refrigeration
- White enamel exterior
- White aluminum and synthetic interior
- Cabinet built to the highest engineering standards
- Embraco Compressor
- ETL approved
- R290 refrigerant



OPTIONAL ACCESSORIES

- CF2ERPK - Baskets - CF71ESG holds 6
- CF71EFG - Glass Food Guard
- CFDW—Dipwell
- CFDW-K - Dipwell Installation Kit
- CFTH - Metal Tub Holder
- CF-NB - Novelty Basket
- CF-NBD - Novelty Basket Divider

WARRANTY

- Compressor 5 years
- Parts & Labor 2 years
(wearable parts and accessories not included)

Celcold freezer merchandisers make selling your ice cream easy and profitable. Celcold's reliable refrigeration system keeps your product properly frozen to ensure quality. With mobility casters, these units can be moved effortlessly, allowing you to maximize sales in any retail environment.

Model #	Net Capacity	Width	Depth	Height	Width Internal	Depth Internal	Height Internal	Basket Capacity	Shipping Weight
CF71ESG	15.3 cu. ft. 433 litres	71" 1803 mm	27.3" 533 mm	32.2" 813 mm	64.8" 1646 mm	21.1" 536 mm	25" 635 mm	6	165 lbs 74.8 kg
Refrigerant	Power	Current	Voltage	Phase	Hertz	Plug	Circuit	Certification	
R290	2/5 hp	2.7 A	110 V	Single	60	Nema 5-15 	Dedicated circuit required	 	

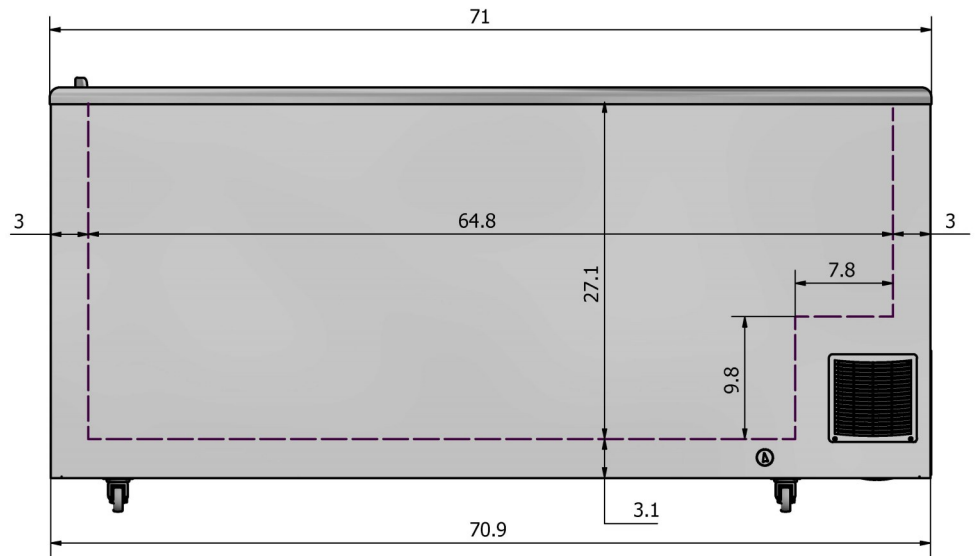
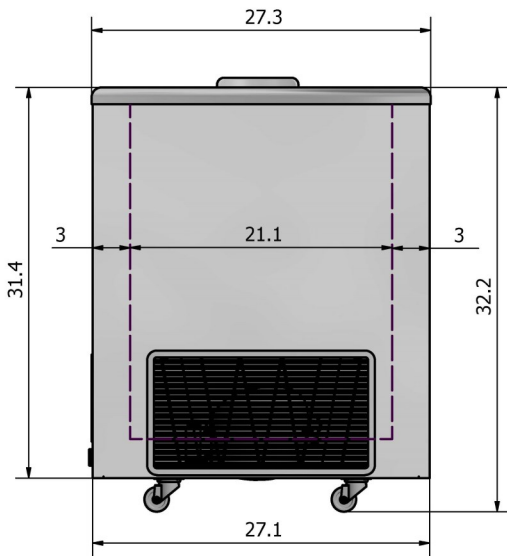

Optional Accessories

CF71EFG Food Guard

- Excellent for building a dipping cabinet
- Glass



CFDW Dipwell

- Stainless steel construction
- Santoprene rubber bumper
- 1" drain and overflow tube included
- Holds 4 - 6 scoops
- Water inlet included
- Easy to clean
- The CFDW-K installation kit is ordered separately



CFDW-K Dipwell Installation Kit

1. Coupling nut
2. Tail piece
3. Leather gasket
4. Barrel valve
5. Male connector
6. Ferrule
7. Plastic tubing
8. Saddle valve
9. Saddle valve and accoutrement



** MOUNTING PLATE FOR DIPPING WELL SHOULD BE INSTALLED ABOVE THE FROSTLINE **

CF2ERPK Basket

- Excellent for building a dipping cabinet
- Powder coated basket holds 2 tubs
- Easy to clean
- Width 10.5"
- Height 14.9"
- Weight 2 lbs



The CF71ESG holds 6 CF2ERPK baskets. Each basket holds 2 Ropak tubs of ice cream.



CF-NB with CF-NBD Novelties Basket

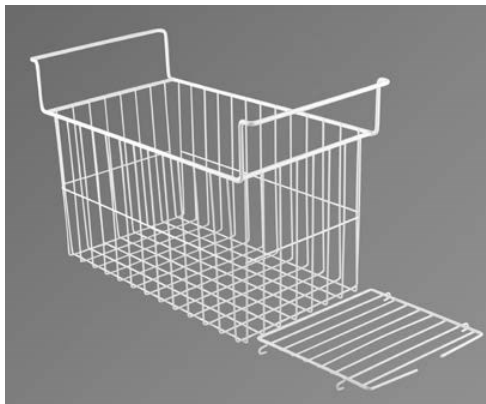

- Easy to clean
- Width 10.75"
- Height 9.25"
- Weight 2 lbs
- CF-NBD Dividers sold separately

CFTH Metal Tub Holder



- Easy to clean
- Holds 2 tubs
- Width 10"
- Height 4"
- Weight 2 lbs

	Application	Height With Handle	Height Without Handle	Width	Depth	Handle Height	Handle Width
CF2ERPK	2 Ropak Tubs	14.9"	11 1/4"	10.5"	22"	4 3/4"	6 1/4"
CF-NB	Novelties Basket	12.25"	9.25"	10 3/4"	22"	3"	
CFTH	Metal Tub Holder	4"	1"	10"	22"	5"	9.5"